

OFDM-CDMA 시스템에서 부분병렬변환을 이용한 PAPR 감쇄기법

정희원 주양익*, 이연우*, 차균현*

Peak-to-Average Power Ratio Reduction by Partial Parallel Transform in an OFDM-CDMA System

Yang-Ick Joo*, Yeonwoo Lee*, Kyun Hyon Tchah* *Regular members*

ABSTRACT

In this paper, an effective peak power reduction scheme for a downlink OFDM-CDMA system is proposed. Using the *partial parallel transform* (PPT) structure, peak-to-average power ratio (PAPR) can be reduced. The patterns of inputs of Inverse Fast Fourier Transform (IFFT) are more randomized in this structure by allotting the subcarriers to each users. At the cost of complexity, we can obtain reduced PAPR and multiple access interference (MAI). Computer simulations are carried out from the viewpoint of PAPR and demonstrated the improved PAPR performance.

I. Introduction

As the increments of the demands for wireless broadband multimedia communication systems are anticipated and wired networks are not sufficient to support the extension to wireless ones with mobility, because of harsh mobile radio channels, and thus, the high quality of service (QoS) required in wired networks cannot be preserved.

For broadband multimedia mobile communication services, it is required to transmit a large amount of data and the high transmission rate must be available. To achieve such a high data rate transmission, Orthogonal Frequency Division Multiplexing (OFDM) has been proposed. As the multiple access techniques for this multiplexing scheme, there has been increasing interest recently in a combination of code division and OFDM techniques, such as MC-CDMA, MC-DS-CDMA,

and MT-CDMA, and these schemes are described in ^[1].

However, since each multicarrier symbol is a sum of modulated sinusoids of random phase, provided the number of sinusoids is large, the amplitude distribution of the real and imaginary part of resultant signal will tend to become Gaussian by central limit theorem. The result is that there is a finite probability of very large amplitude excursions, which tends to make multicarrier modulation schemes have peak-power problems and, at last, sensitive to nonlinear distortion.

A number of different methods have been proposed to alleviate this PAPR problem of OFDM signals. These methods are classified into PAPR reduction with distortion and distortionless PAPR reduction^[8]. The first set of techniques, as [5], is to clip the signal at the transmitter to the desired level. Since this approach is the simplest way, it is widely used although it is known to

* 고려대학교 전자공학과 차세대 이동통신 연구실(yiju@mail.korea.ac.kr)
논문번호: 00211-0616, 접수일자: 2000년 6월 16일

degrade the BER performance and to increase the out-of-band radiation. The latter methods reduce the symbol PAPR prior to the nonlinear device without increasing BER. These methods typically achieve lower PAPR. However, as in [2], [3] and [4], these methods need the information bits additionally to announce to receiver the process for reducing PAPR and take long time in processing to reduce PAPR.

In this paper, an effective PAPR reduction scheme by randomizing the input pattern of IFFT is proposed. As the second approach explained above, this operation is executed prior to the nonlinear device. This proposed method does not summing the users' data but assigning some subcarriers to each user, and then they are inverse Fourier transformed in parallel. Since the input patterns of IFFT are randomized not only data symbols but also orthogonal spreading codes, the resultant transmitting signal's PAPR values can be reduced effectively.

This paper is organized as follows: Section II describes the proposed downlink OFDM-CDMA system model, which is considered all through this paper. In Section III, we show the simulation results. Finally, in Section IV, conclusion remarks are given.

II. Partial Parallel Transformed OFDM-CDMA System

In this paper, we propose a new downlink OFDM-CDMA structure that allocates several subcarriers to each user and inverse Fast Fourier transforms simultaneous active users' data as shown in Fig. 1 and the proposed system is illustrated in Fig. 2. At the transmitter, as shown in Fig. 2(a), the initial data stream is serial-to-parallel converted to lower rate streams. Each branch is spread by orthogonal spreading sequence, $\mathbf{c}^{(l)} = [c_1^{(l)}, c_2^{(l)}, \dots, c_L^{(l)}]$, in the time domain and then the second serial-to-parallel conversion is executed, where $\mathbf{d}^{(l)} = [d_1^{(l)}, d_2^{(l)}, \dots, d_M^{(l)}]$ denotes M data symbols of l th user, $l=1, 2, \dots, K$. Assuming K

active users, $1 \times KL$ spread symbols are inputs to the same $K_{max} \cdot L$ -pt IFFT block, where K_{max} is the maximum number of users and L is the period of orthogonal spreading sequence. Hence, when the number of active users are smaller than the maximum number of users, i.e., $K < K_{max}$, $(K_{max} - K) \cdot L$ zeroes are padded at the end of input vector. The outputs of M IFFT blocks are parallel-to-serial converted and transmitted. BPSK modulation is utilized to simplify the presentation of the new system, but other modulation techniques are equally applicable. At the receiver, given in Fig. 2(b), the received signal, \mathbf{r} is Fast Fourier transformed and despread by user-specific sequences. And then, the resultant data is decided by the maximum correlation value in each FFT block. Finally, decided data symbols are parallel-to-serial converted to resultant data stream. In this process, frequency-divided users' information make it easy to detect own signal, accordingly, MAIs are reduced effectively.

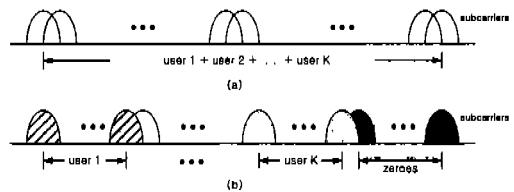

Fig. 1 Input Data Structures of IFFT in (a) conventional OFDM-CDMA and (b) PPT-OFDM-CDMA System

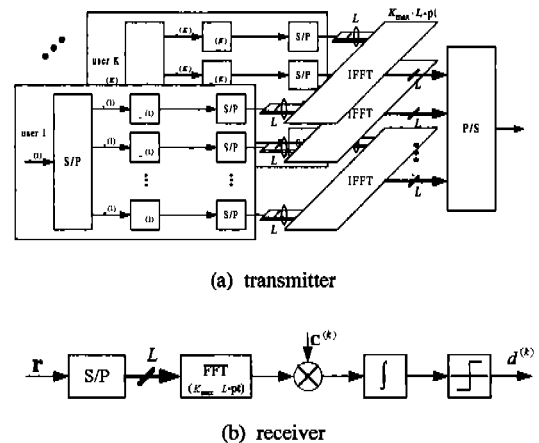

Fig. 2 Partial Parallel Transformed OFDM-CDMA system

Baseband transmission signal at transmitter can be written as

$$s = [\mathbf{g}_1 \mathbf{g}_2 \dots \mathbf{g}_M], \tag{1}$$

where \mathbf{g}_m is the outputs of m -th branch's $K_{\max} \cdot L$ -pt IFFT block and represented as follows:

$$\mathbf{g}_m = \text{IFFT} [d_m^{(0)}c_1^{(0)} \ d_m^{(0)}c_2^{(0)} \ \dots \ d_m^{(0)}c_L^{(0)} \ d_m^{(2)}c_1^{(2)} \ \dots \ d_m^{(2)}c_L^{(2)} \ \dots \ d_m^{(K)}c_1^{(K)} \ \dots \ d_m^{(K)}c_L^{(K)} \ 0 \ 0 \ \dots \ 0], \tag{2}$$

In our discussion, the guard interval and the influence of intersymbol interference (ISI) are excepted, since our interest is on the PAPR property of the signal.

The received signal, \mathbf{r} , especially m -th branch's signal \mathbf{r}_m is represented as follows:

$$\mathbf{r}_m = \mathbf{h}_m \mathbf{g}_m + \mathbf{n}_m, \tag{3}$$

where \mathbf{h}_m is the impulse response of the corresponding channel for m -th branch's output and \mathbf{n}_m is the AWGN term for m -th branch's. Although the proposed system has large complexity, since each users is distinguished by user-specific spreading sequences and assigned subcarrier frequencies, PPT-OFDM-CDMA system can reduce the MAI by the effects of CDM and FDM.

In the conventional systems, their inputs are always organized into the same sum of sequences multiplied by random data symbols. However, in this proposed system, the inputs of IFFT blocks are randomized not only in data symbols but orthogonal spreading sequences, thus the resultant transmission signals' PAPR values can be reduced

1) In spite of these advantages, because of the limits on the number of simultaneous users and allotted subcarriers caused by complexity problem,

1) This philosophy can be easily understood in time to frequency conversion in FFT. The input with regular pattern in time domain introduces result with large peak value in frequency region.

it can be used in the system which has relatively small number of simultaneous users and does not required too many subcarriers such as the wireless LAN environment.

III. Simulation Results

Since orthogonal sequence sets can cancel the crosscorrelation, they are preferred as the spreading sequences and have no MAI factor over an AWGN channel. An orthogonal set of Walsh-Hadamard sequences can be recursively generated by

$$\mathbf{H}_{2N}^W = \frac{1}{\sqrt{2}} \begin{bmatrix} \mathbf{H}_N^W & \mathbf{H}_N^W \\ \mathbf{H}_N^W & -\mathbf{H}_N^W \end{bmatrix}, \mathbf{H}_2^W = \frac{1}{\sqrt{2}} \begin{bmatrix} + & + \\ + & - \end{bmatrix}. \tag{4}$$

In a similar manner, we can obtain Golay complementary sequences as follows:

$$\mathbf{H}_{2N}^C = \frac{1}{\sqrt{2}} \begin{bmatrix} \mathbf{H}_N^C & \bar{\mathbf{H}}_N^C \\ \mathbf{H}_N^C & -\bar{\mathbf{H}}_N^C \end{bmatrix}, \mathbf{H}_2^C = \frac{1}{\sqrt{2}} \begin{bmatrix} + & + \\ + & - \end{bmatrix}, \tag{5}$$

where $\bar{\mathbf{H}}_N^C$ is composed of \mathbf{H}_N^C of which the right half columns are reversed, e.g., if $\mathbf{H}_N^C = [\mathbf{A}_N \ \mathbf{B}_N]$ where \mathbf{A}_N and \mathbf{B}_N are $N \times N/2$ matrices, then $\bar{\mathbf{H}}_N^C \equiv [\mathbf{A}_N \ -\mathbf{B}_N]$. It readily be shown that

$$\mathbf{H}_N^C \cdot \mathbf{H}_N^{C^T} = \mathbf{I}_N, \tag{6}$$

where \mathbf{I}_N denotes the $N \times N$ identity matrix, thus the matrix given above is orthogonal^[7].

In the continuous time domain, PAPR of transmission signal, $s(t)$, is defined as follows:

$$\lambda = \max |s(t)|^2 / \frac{1}{T_s} \int_0^{T_s} |s(t)|^2 dt, \tag{7}$$

where T_s is an OFDM symbol period.

Based on the proposed method, computer simulations have been carried out. Orthogonal sequences with length 16 are randomly selected in

either Walsh-Hadamard or Golay complementary sequence sets and spread each users data. Data in each user block is paralleled into 8 branches (1/8 serial-to-parallel conversion).

According to the number of active users, probability that an OFDM-CDMA symbol exceeds specific PAPR λ_0 is induced. Expected in [2], the PAPR values for Walsh-Hadamard code are reduced gradually as the number of active users is increased and those for Golay complementary code are relatively constant. Anyway, in the case of any number of active users, the PAPR for PPT-OFDM-CDMA structure is smaller than that for conventional OFDM-CDMA system. When the number of active users is greater than or equal to 8, Walsh-Hadamard code shows the best

performance. Hence, without loss of generality, PPT-structure applying Walsh-Hadamard code is suitable for the multicarrier system requiring a small number of subcarriers and simultaneous active users.

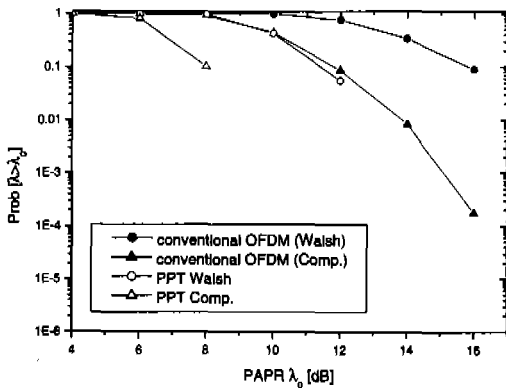

Fig. 3 Probability that an OFDM-CDMA symbol exceeds specific PAPR λ_0 with 2 active users

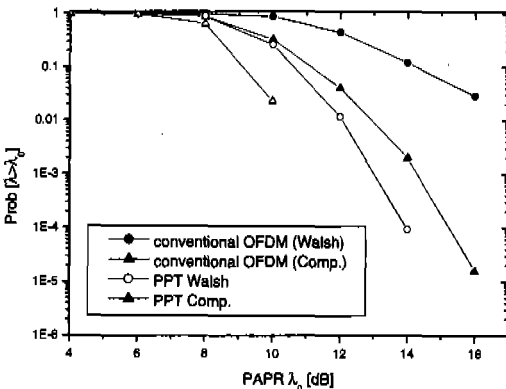

Fig. 4 Probability that an OFDM-CDMA symbol exceeds specific PAPR λ_0 with 4 active users

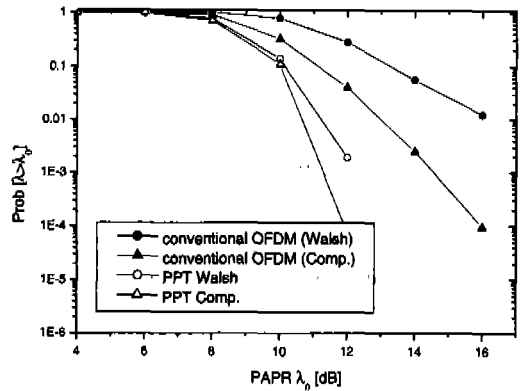

Fig. 5 Probability that an OFDM-CDMA symbol exceeds specific PAPR λ_0 with 6 active users

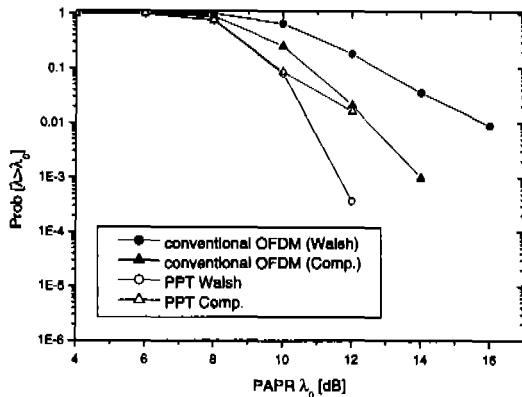

Fig. 6 Probability that an OFDM-CDMA symbol exceeds specific PAPR λ_0 with 8 active users

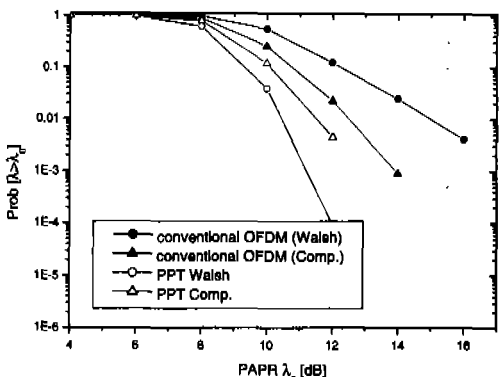

Fig. 7 Probability that an OFDM-CDMA symbol exceeds specific PAPR λ_0 with 10 active users

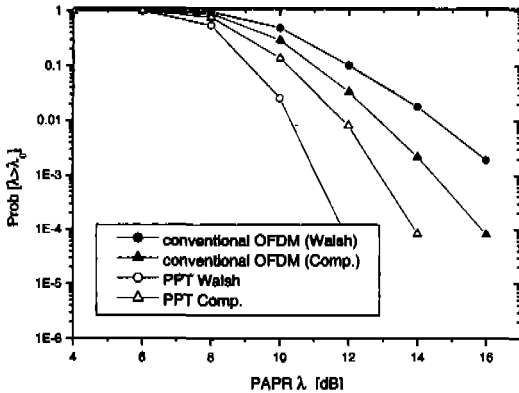

Fig. 8 Probability that an OFDM-CDMA symbol exceeds specific PAPR λ_0 with 12 active users

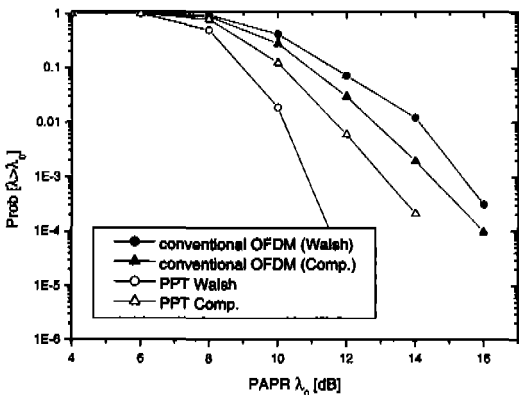

Fig. 9 Probability that an OFDM-CDMA symbol exceeds specific PAPR λ_0 with 14 active users

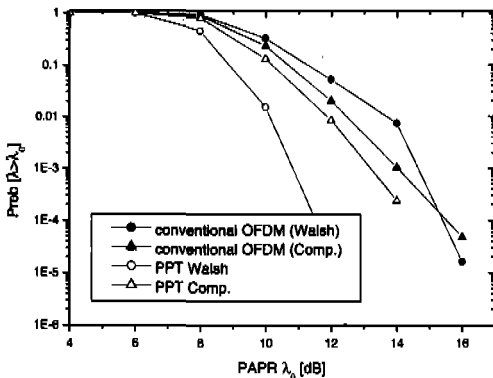

Fig. 10 Probability that an OFDM-CDMA symbol exceeds specific PAPR λ_0 with 16 active users

IV. Conclusions

So far, we have considered the PAPR property in the downlink PPT-OFDM-CDMA system and demonstrated the performance of proposed scheme. Though it has large complexity of m times of conventional downlink OFDM-CDMA system, since this system can applied to the fixed system with small number of active users and subcarriers such as wireless LAN environment, the complexity of proposed system is not fatal. In the sequel, subcarrier-devided data allocation prior to IFFT modulation randomizes the regular patterns of spread signals, it can suppress the peak power of IFFT output signal. Therefore, we can say that the proposed scheme is effective PAPR reduction method and it may be able to mitigate the nonlinear distortion of the multicarrier signals.

References

- [1] S. Hara and R. Prasad, "Overview of Multi-Carrier CDMA," *IEEE Commun. Mag.*, Vol. 35, No. 12, pp. 126-133, Dec 1997.
- [2] H. Ochiai and H. Imai, "OFDM-CDMA with Peak Power Reduction Based on the Spreading Sequences," in *Proc. Int. Conf. on Communications (ICC '98)*, Atlanta, pp. 1299-1303, June 1998.
- [3] S. H. Müller and J. B. Huber, "A Novel Peak Power Reduction Scheme for OFDM," in *Proc. PIMRC '97*, Helsinki, pp. 1090-1094, Sept. 1997.
- [4] S. G. Kang, J. G. Kim and E. K. Joo, "A Novel Subblock Partition Scheme for Partial Transmit Sequence OFDM," *IEEE Trans. on Broadcasting*, Vol. 45, No. 3, pp. 333-338, Sept. 1999.
- [5] R. O'Neill and L. B. Lopes, "Envelope Variations and Spectral Splatter in Clipped Multicarrier Signals," in *Proc. IEEE PIMRC*, Vol. 1, Toronto, Canada, pp. 71-75, Sept. 1995.
- [6] B. M. Popovic, "Spreading Sequences for Multicarrier CDMA Systems," *IEEE Trans. on*

Commun., Vol. 47, No. 6, pp. 918-926, June 1999.

- [7] M. J. E. Golay, "Complementary series," *IRE Trans. Inform. Theory*, Vol. IT-7, pp. 82-87, April 1961.
- [8] Jose Tellado-Mourello, *Peak to Average Power Reduction for Multicarrier Modulation*, Ph. D. Thesis, Stanford University, USA, Sept. 1999.
- [9] Yang-Ick Joo, Yeonwoo Lee, Kyun Hyon Tchah, "New Peak Power Reduction Scheme for an OFDM-CDMA System," *Journal of Korean Institute of Communication Sciences (KICS)*, Vol. 25, No. 7, July 2000.

차 균 현(Kyun Hyon Tchah)

정회원



1965년 2월 : 서울대학교

전기공학과 학사

1967년 6월 : 미국 일리노이

공과대학 석사

1976년 6월 : 서울대학교

전자공학과 박사

1977년 3월~현재 : 고려대학교 전자공학과 교수

1998년 1월~1998년 12월 : 한국통신학회 회장

1998년 4월~현재 : 한국전자통신연구원 부이사장

<주관심 분야> 통신 이론, 이동 통신, 위성 통신,
이동 멀티미디어 시스템

주 양 익(Yang-Ick Joo)

정회원

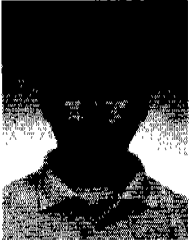

1998년 2월 : 고려대학교

전자공학과 학사

2000년 8월 : 고려대학교

전자공학과 석사

2000년 9월~현재 : 고려대학교

전자공학과 박사과정

<주관심 분야> Spread Spectrum 시스템, OFDM-CDMA 시스템, 다중 사용자 검출방식, 차세대 이동통신 시스템

이 연 우(Yeonwoo Lee)

정회원

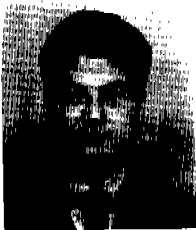

1992년 2월 : 고려대학교

전자공학과 학사

1994년 2월 : 고려대학교

전자공학과 석사

2000년 2월 : 고려대학교

전자공학과 박사

2000년 9월~현재 : 영국 Univ. of Edinburgh post doc. 과정

<주관심 분야> Spread Spectrum 시스템, 멀티미디어 CDMA 시스템, 차세대 광대역 이동 멀티미디어 통신 시스템