

論 文

PN-SS 통신시스템에서 狹帶域 干涉信號의 除去方式에 關한 研究

正會員 金 東 吉* 正會員 金 元 厚**

A Study on Narrowband Interference Rejection in PN-SS System

Dong Kil KIM* and Won Hoo KIM**, *Regular Members*

要 約 DS대역확산 통신 수신기의 성능은 디지털 백색화 여파기를 사용하여 개선시킬 수 있다. 본 연구에서는 출력의 hard-limiter에서 검출한 신호를 입력으로 제하시켜 간섭과 잡음성분만을 백색화하는 디지털 제화 백색화 여파기를 제안하고 여파기의 계수계산 방법에 관하여 기술하였다. SNR과 BER에 관한 식을 유도하였으며 총래의 디지털 백색화 여파기와 비교하였다. 컴퓨터 시뮬레이션 결과 오류특성은 총래의 방식에 비해 크게 향상된 것으로 나타났다.

ABSTRACT The performance of direct-sequence spread spectrum(DS-SS) receiver may be enhanced by using the digital whitening filter. In this paper, the hard limited feedback whitening filter that whiten the interference and noise alone is proposed to obtain the additional resistance to narrowband interference. The recursive solution for the calculation of tap weights is presented and the expression for SNR and BER is derived and compared with the conventional digital whitening filter. As the result of computer simulation it is proved that the error performance is improved considerably.

1. INTRODUCTION

This paper is concerned with the bandwidth spreading techniques wherein a communications system utilizes far more than the minimum required bandwidth for information transfer^{(1),(2)}. Though this large bandwidth may be devastating to spectrum conservation, the performance benefits obtained wi-

th spread spectrum for outweigh the cost in bandwidth for many applications. Some of these applications are anti-jamming, multiple access communications, message privacy and navigations^(3~6).

Unfortunately not only are these systems hard to implement but also the possibility of demodulation errors degrades considerably in the presence of narrowband interference, partial band interference, and jamming, and due to design errors resulting in correlation loss and synchronization loss. The recent advances in SAW devices, SAW and efficient synchronization circuitry, should devote much of the implementation and synchronization difficulties^{(7),(8)}. However these remains the question of more efficient method to reduce the demodula-

* 韓國電氣通信研究所

Korea Electrotechnology & Telecommunications Research Institute, Daejeon 300-01, Korea

** 韓國航空大學電子工學科

Dept. of Avionics Engineering, Hankuk Aviation College, Seoul 122, Korea

論文番號 : 84-09 (收受 1983. 12. 2)

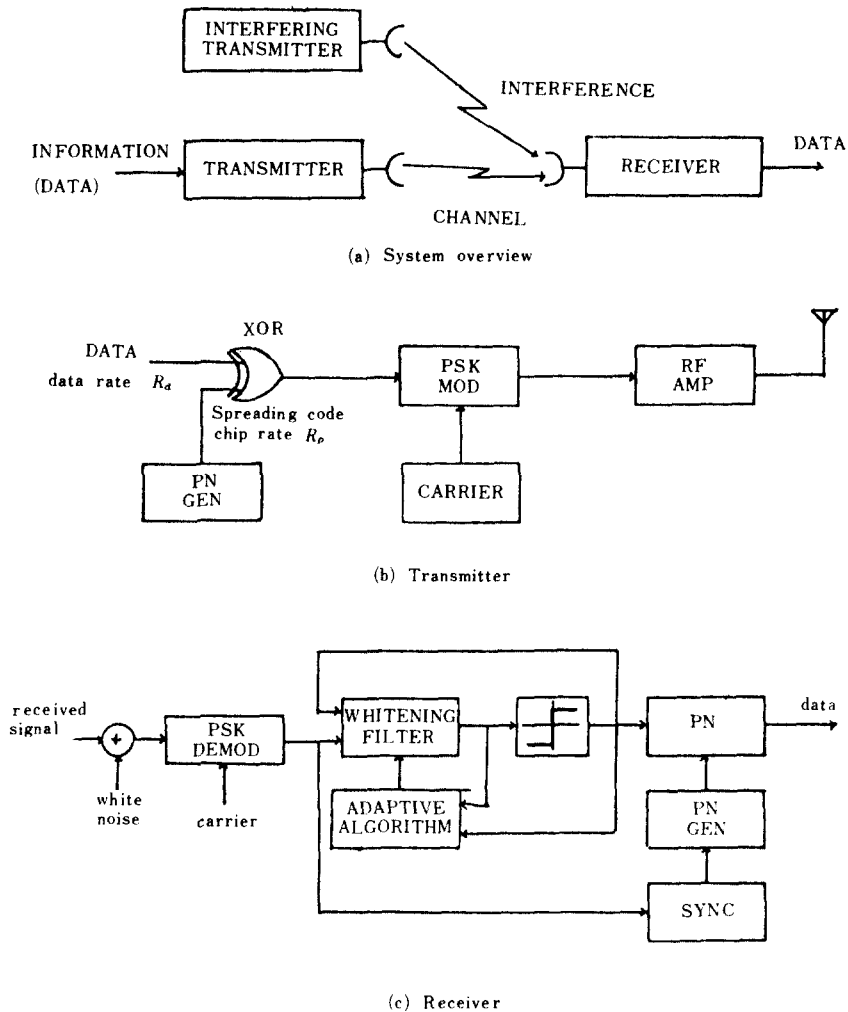

Fig.1 PN spread spectrum communication system.

tion errors in a spread spectrum(SS) channel with severe interference(or jamming).

Narrowband interference rejection is achieved by either increased processing gain or electronic signal rejection. Since the increased processing gain decrease the bandwidth efficiency, several authors have applied digital whitening filters to reduce demodulation errors in narrowband interference^{19, 20, 21}. However, the most common methods of interference suppression are equivalent to whitening the signal, noise and jammer. Since interference as well as signal is whitened, the performance is somewhat inferior to that obtained using other elec-

tronic rejection circuitry.

In this paper, the digital whitening filter with the feedback from the hard limiter will be used in order to whitening interference only and the conventional and feedback digital whitening filter in different jamming situations will be compared.

2. ANALYSIS MODEL

2.1 System Model

Our model under study is illustrates in Fig1. For convenience, the system is partitioned into three major elements : transmitter, channel and receiver.

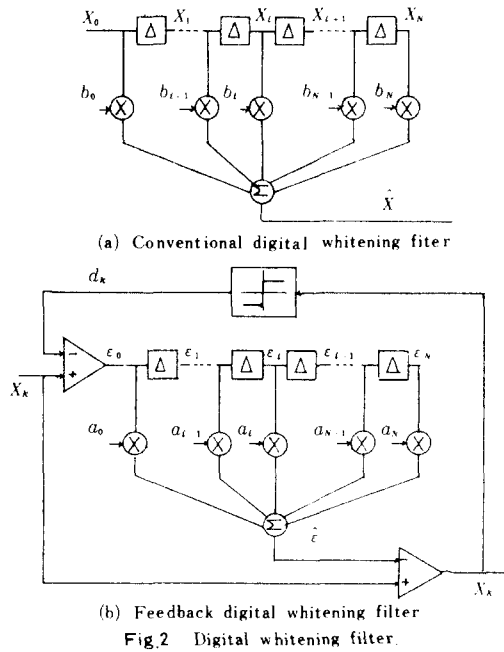

In the transmitter, the data signal (information) $d_k(t)$ is a sequence of rectangular pulses of duration T . The k -th pulse has amplitudes $d_k(t) = U$ for $nT \leq t \leq (n+1)T$ where $U \in \{+1, -1\}$. This data signal is spread by a code waveform $P_k(t)$ using the exclusive-OR gate and then is phase modulated shown in Fig 1 (a).

The l -th code pulse has amplitude $P_k(t) = P$ for $lT \leq t \leq (l+1)T_c$ where $P \in \{+1, -1\}$. It is assumed that there are N code pulses in each data pulse ($T = NT_c$) and the period of the signature sequence is N . The transmitted signal is given by

$$S = 2\sqrt{2P} d_k(t) P_k(t) \cos(2\pi f_c t + \theta_k) \quad (1)$$

where P is the power in each of the k transmitted signals, f_c is the center frequency and θ_k is the phase angle introduced by the modulator-spreader.

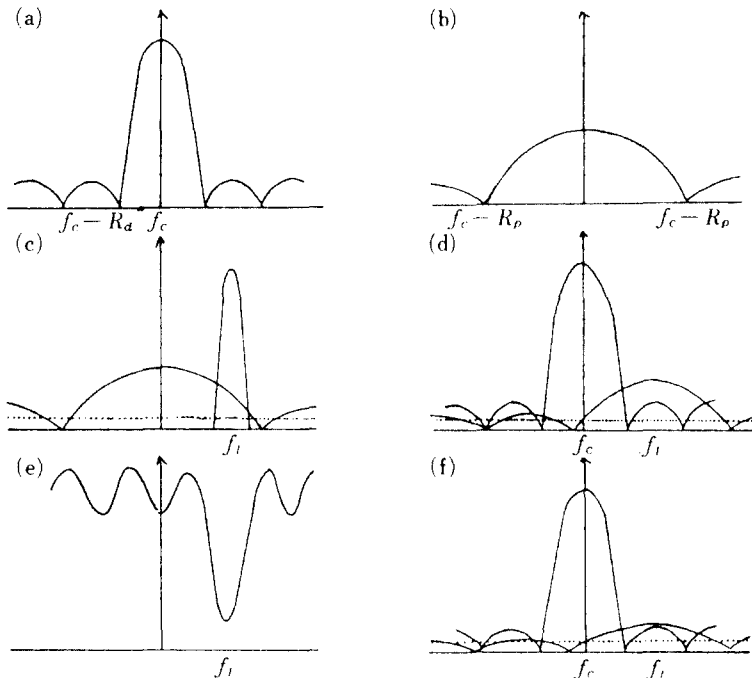

Fig.3 Spread spectrum transmission
 (a) Data signal (information),
 (b) Transmitted spread spectrum,
 (c) Received spectrum,
 (d) Despreading spectrum,
 (e) Transfer function of the the digital whitening filter,
 (f) Spectrum after digital whitening.

The receiver for this system consist of RF stage, Phase demodulator, PN matched filter, PN Generater and digital whitening filter. Referring to the receiver shown in Fig. 3, the PNMF acquires the input signal from digital whitening filter used for narrow interference rejection. In this paper, the feedback loop from the decision circuitary is used in order to improve the performance. Fig 2 illustrates the conventional digital whitening filter and the feedback digital whitening filter.

2.2 Signal Format

Narrowband jamming and interference due to other users in spread spectrum communication systems considerably affect the performance of the system. In this study, it is assumed that the narrowband interference is multiple CW interference and narrowband Gaussian interference. In a narrowband interference environment the received wideband signal can be expressed as

$$\begin{aligned}
 x_k &= S_k + q_k + n_k \\
 &= UP_k + \sum_{m=1}^M c_m \cos(2\pi f_m k \Delta t + \Phi_m) + n_k
 \end{aligned}
 \tag{2}$$

where

- q_k : narrowband interference,
- n_k : zero mean white Gaussian noise with a variance σ^2 ,
- S_k : transmitted signal,
- U : information symbol,
- P_k : modulated PN sequence,
- c_m : amplitude of narrowband jamming,
- f_m : sampling frequency of narrowband jamming
- Φ_m : phase of the narrowband jamming distributed uniformly over the range $(-\pi, \pi)$,
- Δt : sampling interval.

The interference representation shown in equation(1) is valid for multiple tone CW interference and narrowband Gaussian interference^[5]. The spectrum shape in the narrowband interference environment is represented by Fig 3.

3. COEFFICIENT CALCULATION

The coefficient calculation method in the conventional digital whitening filter is to estimate the interference q_k and subtract this estimate from

r_k . In this case, the resulting equations for the tap coefficient b_k is

$$\sum_{l=1}^n b_{k-l} \rho_{k-l} = \rho_k
 \tag{3}$$

where

$$\rho_k = \frac{1}{M} \sum_{l=1}^M r_k r_{k-l}
 \tag{4}$$

and

$$r_k = S_k + q_k + n_k
 \tag{5}$$

However, it is shown that the entire received signal is whitened rather than just the noise and jammer.

In order to whiten the jammer and noise, the hard-limited feedback digital whitening filter in Fig 1 was constructed. Now consider the error signal is

$$\epsilon_k = x_k - d_k
 \tag{6}$$

and then r_k in (3) is substituted to ϵ_k .

Let $\{\epsilon_k\}$ be a stationary time series, and suppose that one have available the segment $\epsilon_0, \epsilon_1, \dots, \epsilon_{k-1}$ and wishes to estimate ϵ_n . Thus one seeks coefficients $a_{n, n-1}$ such that

$$\hat{\epsilon}_{n/n-1} = - \sum_{l=0}^{n-1} a_{n, n-l} \epsilon_l
 \tag{7}$$

By the orthogonality principle,

$$E\{(\epsilon_n - \hat{\epsilon}_{n/n-1})\epsilon_j\} = 0 \text{ for } j=0, 1, \dots, n-1
 \tag{8}$$

so that

$$\begin{aligned}
 E\{\epsilon_n \epsilon_j\} &= - \sum_{l=0}^{n-1} a_{n, n-l} E\{\epsilon_l \epsilon_j\} \\
 &= a_{n, n-l} \mu_n^l
 \end{aligned}
 \tag{9}$$

or

$$R_{n, j} = - \sum_{l=0}^{n-l} a_{n, n-l} R_{l, j} = - a_{n, n} R_{l, j}
 \tag{10}$$

where $a_{n, n} = [1 \ a_{n, 1} \ \dots \ a_{n, n}]$ is the vector of coefficients, $\mu_n = [\mu_1 \ \mu_2 \ \dots \ \mu_n]$ is a vector describing the mean square error, and R_n is a $N \times N$ symmetric Toeplitz matrix, representing the error signal covariance $E\{\epsilon_i \epsilon_j\}$

$$R_p = [\tau_{i-j}]_{i,j=1,\dots,p} = \begin{pmatrix} \tau_0 & \tau_1 & \dots & \tau_n \\ \tau_1 & \tau_0 & \dots & \tau_{n-1} \\ \vdots & \vdots & \ddots & \vdots \\ \tau_n & \tau_{n-1} & \dots & \tau_0 \end{pmatrix} \quad (11)$$

The associated mean square error is

$$\begin{aligned} \xi(C_p) &= E\{\varepsilon_n - \hat{\varepsilon}_{n/n-1}\} \{\varepsilon_n - \hat{\varepsilon}_{n/n-1}\} \\ &= E\{\varepsilon_n \hat{\varepsilon}_n\} - 2E\{\varepsilon_n \hat{\varepsilon}_{n/n-1}\} \\ &\quad + E\{\varepsilon_{n/n-1} \hat{\varepsilon}_{n/n-1}\} \\ &= \mu_0 - 2\underline{a}_n \mu_n + \underline{a}_n R_n \underline{a}_n' \end{aligned} \quad (12)$$

Minimization of the mean square error between ε_k and $\hat{\varepsilon}_k$. $\text{Min} \xi(\underline{a}_p)$, yields the following equations

$$\underline{a}_{n,n} R_n = \underline{\mu}_n \text{ or } \underline{a}_{n,n} = R_n^{-1} \underline{\mu}_n \quad (13)$$

To find a recursive solution for a_p , observe the values $a_{n,n}$ and μ_n have been found and we seek the quantities $a_{n,n+1}$ and μ_{n+1} . Then

$$\begin{aligned} [1 \ a_{n,1} \dots a_{n,n} 0] \begin{pmatrix} \tau_0 & \tau_1 & \dots & \tau_{n+1} \\ \tau_1 & \tau_0 & \dots & \tau_n \\ \vdots & \vdots & \ddots & \vdots \\ \tau_{n+1} & \tau_n & \dots & \tau_0 \end{pmatrix} \\ = [\mu_n 0 \dots a_n] \end{aligned} \quad (14)$$

Since the above equation is the Toeplitz structure

$$\begin{aligned} [0 \ a_{n,n} \dots a_{n,1} 1] = \begin{pmatrix} \tau_0 & \tau_1 & \dots & \tau_{n+1} \\ \tau_1 & \tau_0 & \dots & \tau_n \\ \vdots & \vdots & \ddots & \vdots \\ \tau_{n+1} & \tau_n & \dots & \tau_0 \end{pmatrix} \\ = [a_n 0 \dots \mu_n] \end{aligned} \quad (15)$$

Table 1 Parameters used in computer simulation.

Parameter	Values
Processing Gain	$L = 2047$ chips
Order of the whitening Filter (number of taps on each side of the transversal filter)	$N = 4, 8, 12$
Offset Frequency of the Tone jammer from the carrier	$f_m = \frac{m}{1,000}$ ($m = 1, 2, \dots, 100$)
Amplitude of the Tone Jammer	$C_m = 0.5$
phase of the Interfering Tongs	random values distributed uniformly over the range $(-\pi, \pi)$
Standard Deviation of white Gaussian Noise	$0 = 0.1, 0.5, 1.0$
Spread Chip Rate	11.232MHz
Data Modulation Rate	216kb/s
Input Carrier Frequency	116MHz
Data Modulation Format	Biphase

Table 2 Comparison of the tap weight ($N=4, K=380$)

Filter Type	1.000	0.104	0.134	-0.053	0.304
Conventional Filter	1.000	0.030	0.121	-0.012	0.288
Hard-limited Feedback Filter					

$$\begin{aligned} \left[1 \ a_{n,1} \dots \frac{a_n}{\mu_n} \dots a_{n,n} \dots \frac{a_n}{\mu_n} \ a_{n-1} \dots \frac{a_n}{\mu_n} \right] \\ \begin{pmatrix} \tau_0 & \tau_1 & \dots & \tau_{n+1} \\ \tau_1 & \tau_0 & \dots & \tau_n \\ \vdots & \vdots & \ddots & \vdots \\ \tau_{n+1} & \tau_n & \dots & \tau_0 \end{pmatrix} = \left[\mu_n \frac{a_n^2}{\mu_n} \ 0 \ \dots \ 0 \right] \end{aligned} \quad (16)$$

So the recursive solution for the eq.(13) is given by

$$a_n = \tau_{n+1} + \sum_{i=1}^{n-1} a_{n,i} \tau_{n+1-i} \quad (17)$$

$$a_{n+1,i} = a_{n,i} - \frac{n}{\mu_n} a_{n,n+1-i} \quad i = 1, \dots, n \quad (18)$$

$$a_{n+1,n+1} = -\frac{a_n}{\mu_n} \quad (19)$$

$$\mu_{n+1} = \mu_n - \frac{a_n^2}{\mu_n} \quad (20)$$

where

$$a_{11} = -\frac{\tau_1}{\tau_0} \quad \mu_1 = \tau_0 - \frac{\tau_1^2}{\tau_0} \quad (21)$$

Comparing the weights of the conventional filter and the hard-limited feedback filter, the weight of the conventional whitening filter are large since the former are obtained from x_k and the letter $q_k +$

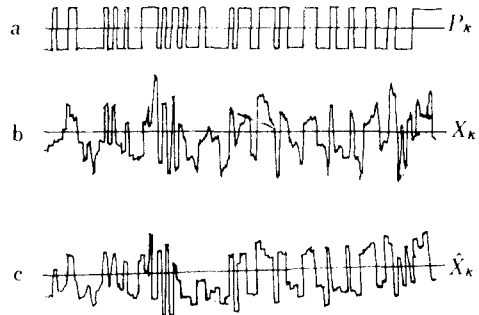

Fig.4 SS signal waveform by computer simulation
(a) PN sequence P_k (b) Received signal X_k
(c) Whitenened signal \hat{X}_k

n_k . For example, in the conditions of table 1, the weights are given as table 2, The SS signal wave form whitened by above algorithm is illustrates in Fig 3 and we can notify the performance improvement intuitively.

4. ERROR RATE PERFORMANCE

4.1 Signal-to-Noise Ratio(SNR)

In this section, the SNR of the hard-limited feedback whitening filter is derived. If the received signal is whitened by it, the error signal is formed as

$$\begin{aligned} \varepsilon_k &= x_k + \sum_{i=1}^n a_i (x_{k-i} - d_{k-i}) \\ &= x_k + \sum_{i=1}^n a_i (q_{k-i} + n_{k-i}) \end{aligned} \quad (22)$$

or

$$\varepsilon_k = UP_k + \sum_{i=0}^n a_i (q_{k-i} + n_{k-i}) \quad (23)$$

where $\{a_i\}$ are the prediction error filter coefficients. The error signal is correlated with the PN code to produce the signal output S; i.e.

$$\begin{aligned} S &= \sum_{k=1}^L \varepsilon_k p_k \\ &= \sum_{k=1}^L \sum_{i=0}^n p_k (q_{k-i} + n_{k-i}) + \sum_{k=1}^L UP_k p_k \end{aligned} \quad (24)$$

where L is the number of chips per symbol and the PN code chips $p_k = \pm 1$. In order to simplify the analysis, an ensemble of the independent PN systems is assumed that

$$E(p_k p_l) = \delta_{k-l} = \begin{cases} 1 & k=l \\ 0 & \text{otherwise} \end{cases} \quad (25)$$

The SNR of the correlation output can be computed from the mean of variance of S . The mean of S is given by $E(S) = UL$. Since $a_0 = 1$ and $E(q_{k-i}) = 0$ and the zero mean noise. The variance of S is given by

$$\begin{aligned} V(S) &= E(S^2) - L^2 \\ &= \sum_{k=1}^L \sum_{i=0}^n \sum_{i'=0}^n a_i a_{i'} E(q_{k-i} q_{k-i'}) + 2LU \end{aligned} \quad (26)$$

Evaluation of $V(S)$ requires the identity

$$E(q_{k-i} q_{k-i'}) = \frac{1}{2} \sum_{m=1}^M c_m^2 \cos(2\pi \Delta t f_m (j-i)) + \sigma^2 \delta_{j-i} \quad (27)$$

using (23) in (22) results in

$$\begin{aligned} V(S) &= \frac{L}{2} \sum_{i=0}^n \sum_{j=0}^n a_i a_j \sum_{m=1}^M c_m^2 \cos \\ &\quad (2\pi \Delta t f_m (j-i)) + L\sigma^2 \sum_{i=1}^n a_i^2 \end{aligned} \quad (28)$$

The power spectrum of the optimum whitening filter given by

$$\begin{aligned} p(f_m) &= \frac{p_n \Delta t}{\left(\sum_{i=0}^n a_i e^{-j2\pi f_m \lambda \Delta t} \right)^2} \\ &= \frac{p_n \Delta t}{\sum_{i=0}^n \sum_{i'=0}^n a_i a_{i'} \cos(2\pi f_m (i-i') \Delta t)} \end{aligned} \quad (29)$$

where

$$p(f_m) = \frac{1}{2} \frac{c_m^2}{\Delta f} \quad (30)$$

substituting (28) and (29) in (30) yields

$$V(S) = LP_n \Delta t \Delta f M = L\sigma^2 \sum_{i=1}^n a_i^2 \quad (31)$$

The SNR of S is then found to be

$$SNR = \frac{L}{\sigma^2 \sum_{i=1}^n a_i^2 + MP_n \Delta f \Delta t} \quad (32)$$

The SNR of conventional spread spectrum system is derived by Hsu⁽⁵⁾

$$SNR' = \frac{L}{(1 + \sigma^2) \sum_{i=1}^n b_i^2 + MP_n \Delta f \Delta t} \quad (33)$$

Notice that a_i is smaller than b_i as explained in Sec. 3, and then SNR is much greater than SNR' .

4.2 Bit Error Rate(BER)

The BER of the BPSK DS-SS communication systems is obtained by the following decision ststistic

$$Z = \pm \sqrt{E} + \sqrt{\sigma^2 \sum_{i=1}^n a_i^2} +$$

$$+ \sqrt{\sum_{i=1}^n a_i^2 \sum_{m=1}^M c_m^2 \cos(2\pi \Delta t f_m (m-i))} \quad (34)$$

where $\pm\sqrt{E}$ is the response to the signal and is positive or negative depending on the identity of the data bit, the second term is a zero mean Gaussian random variable σ^2 , and the last term is the response to the jamming signal. From the (34),

$$\begin{aligned} p^-(\Delta\theta) &= p(z < 0 | +1 \text{ transmitted}, \Delta\theta) \\ &= \frac{1}{2} - \text{erf} \frac{\sqrt{E} - \sqrt{MP_N \Delta f \Delta t}}{\sqrt{\sigma^2 \sum_{i=1}^n a_i^2}} \\ &= \text{erfc} \frac{\sqrt{E} - \sqrt{MP_N \Delta f \Delta t}}{\sqrt{\sigma^2 \sum_{i=1}^n a_i^2}} \end{aligned} \quad (35)$$

and

$$p^+(\Delta\theta) = \text{erfc} \frac{\sqrt{E} + \sqrt{MP_N \Delta f \Delta t}}{\sqrt{\sigma^2 \sum_{i=1}^n a_i^2}} \quad (36)$$

Therefore

$$\begin{aligned} p_e &= \frac{1}{2} p^-(\Delta\theta) + \frac{1}{2} p^+(\Delta\theta) \\ &= \frac{1}{2} \text{erfc} \frac{\sqrt{E} - \sqrt{MP_N \Delta f \Delta t}}{\sqrt{\sigma^2 \sum_{i=1}^n a_i^2}} \\ &\quad + \frac{1}{2} \text{erfc} \frac{\sqrt{E} + \sqrt{MP_N \Delta f \Delta t}}{\sqrt{\sigma^2 \sum_{i=1}^n a_i^2}} \end{aligned} \quad (37)$$

The graphical results which are numerically calculated by computer simulation are shown in Fig 5 - Fig 6 .

5. DISCUSSION AND CONCLUSIONS

An analysis of the performance of the hard-limited feedback whitening filter has been presented for the case of binary PN encoded PSK signal operating in the presence of narrow band jamming or partial band interference. Computer simulation is implemented by means of VAX-11/780 computer.

(1) As shown in Fig 4, SNR increase as the white noise power decrease from 1 to 0.1. Besides, as the order of the filter increase the SAR is improved.

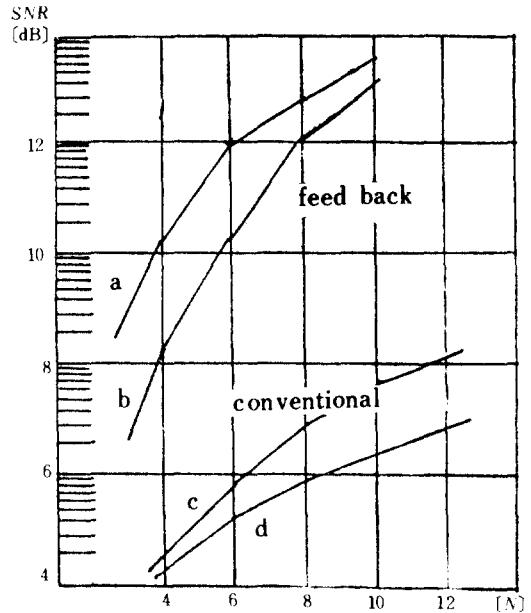

Fig. 5 SNR versus the number of taps
(a, c: $E/\sigma^2 = 15\text{dB}$, b, d: $E/\sigma^2 = 10\text{dB}$)

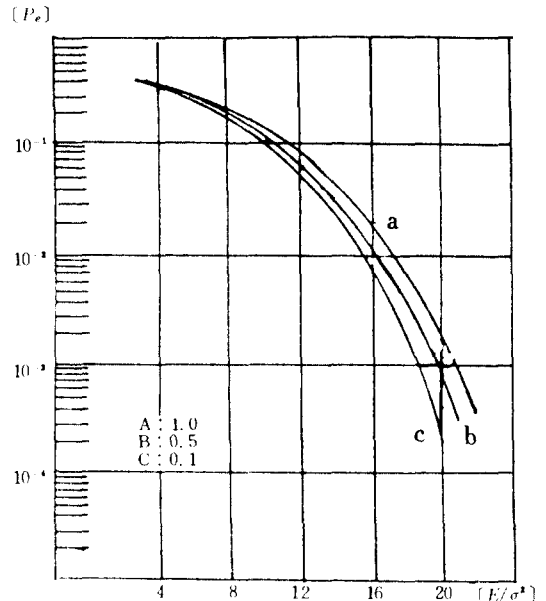

Fig. 6 BER of BPSK DS-SS communication system
($n=4$, $C_m=0.5$).

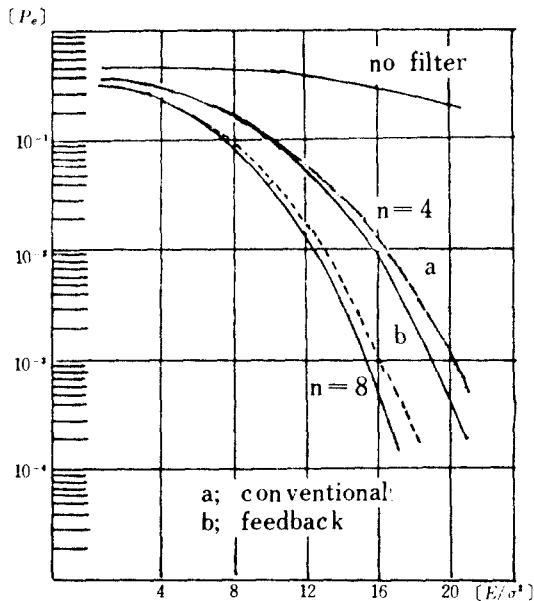

Fig.7 BER of DS-SS interfered by narrowband jamming (with the change of N , $C_n=0.5$).

(2) In Fig 5 and Fig 6, the BER of BPSKSS signal interfered by narrow band jamming are given. It is shown that for various jamming environment digital whitening filter can significantly improve system performance. Comparing the conventional digital whitening filter and the hard-limited feedback whitening filter, the latter is less BER than the former and as the order of the filter is increase, BER become smaller.

Computer simulation of a direct sequencespread spectrum communication system has shown that the hard-limited feedback whitening filter is more effective than the conventional digital whitening filter. The reason of these performance improvement is obtained that although conventional digital whitening filter whiten the entire received signal i.

e. information signal, interference and white Gaussian noise, the hard-limited feedback whitening filter whiten the interference and noise.

REFERENCES

- (1) R. C. Dixon, "Spread spectrum systems," John Wiley, New York, 1969.
- (2) J. K. Holmes, "Coherent spread spectrum systems," John Wiley, 1982.
- (3) R. C. Dixon, "Spread spectrum techniques," IEEE Press, 1976.
- (4) D. R. Anderson and P. A. Wintz, "Analysis of a spread spectrum multiple-access system with a hard-limiter," IEEE Trans. Commun., vol. COM-17, pp. 285-290, Apr. 1969.
- (5) M. B. Pursley, "Performance evaluation of phase-coded spread spectrum multiple-access communication-Part I: System analysis," IEEE Trans. Commun., vol. COM-25, pp. 796-799, Aug. 1977.
- (6) B. Hirotsaki, "Spread-spectrum multiple access data loop," NTC'81.
- (7) P. Das, D. R. Arsenault and Giordano, "Adaptive spread spectrum receiver using SAW technology," Nat. Telecomm. Conf., vol. 1, 1977.
- (8) L. R. Milstein, P. K. Das and D. R. Arsenault, "Narrowband jammer suppression in spread spectrum system using SAW devices," Nat. Telecommun. Conference, pp. 43.2.1-43.2.6, 1978.
- (9) F. A. Hsu and A. A. Giordano, "Digital whitening techniques for improving spread spectrum communication performance in the presence of narrowband interference and jamming," IEEE Trans. Commun. vol. COM-26, no. 2, Feb. 1978.
- (10) L. M. Li and L. B. Milstein, "Rejection of pulsed CW interference in PN spread spectrum systems using complex adaptive filter," IEEE Trans. Commun. vol. COM-31, no. 1, Jan. 1983.
- (11) R. S. Lunayach, "Performance of a direct sequences spread spectrum system with long period and short period code sequence," IEEE Commun. vol. COM-31, no. 3, March 1973.



金 東 吉 (Dong Kil KIM) 正會員
 1960年2月22日生
 1980年~1982年2月: 韓國航空大學
 1982年3月~1984年2月: 韓國航空大學
 大學院
 1982年12月15日現在: 韓國電氣通信研究
 所(教育訓練室)



金 元 厚 (Won Hoo KIM) 正會員
 1935年2月1日生
 1955年4月~1959年3月: 韓國航空大學
 卒業
 1973年3月~1975年2月: 韓陽大學校大
 學院(工學碩
 士) 進
 1962年3月~現在: 韓國航空大學校電子
 工學科 教授, 本學
 會常任理事